

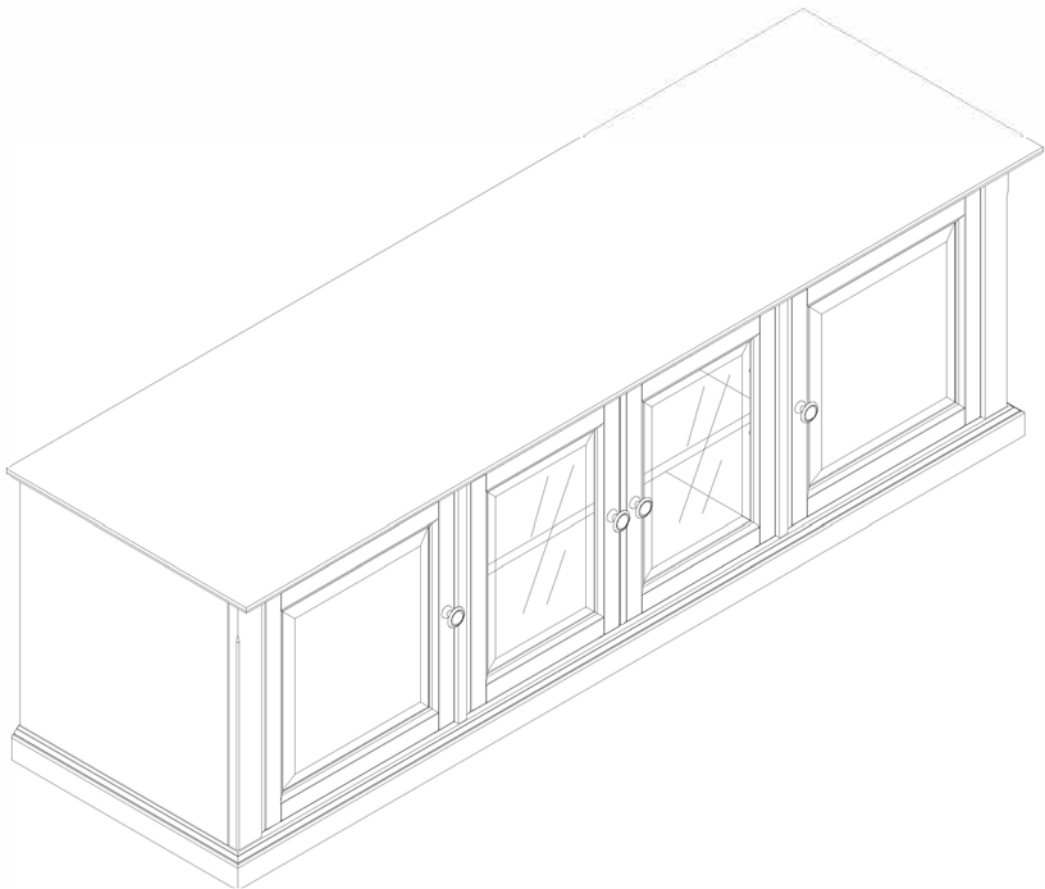

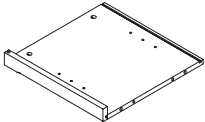

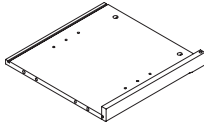

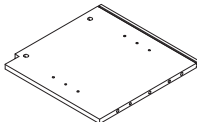
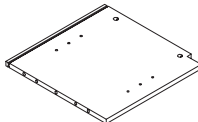
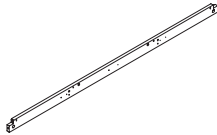
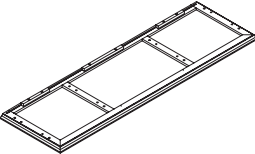
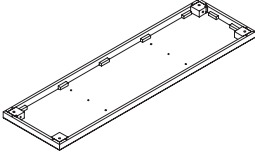
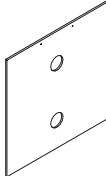
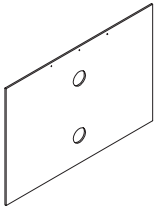
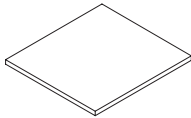
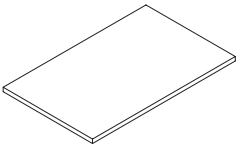

**60" Low Profile TV Stand
CF100360**

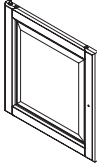
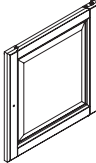
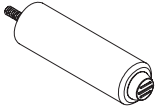
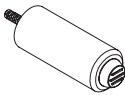

PART LIST

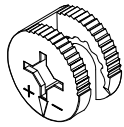
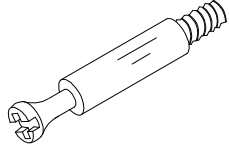
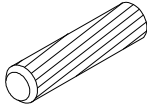
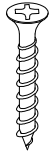
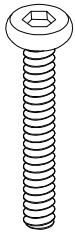
<p>A</p> 	<p>B</p> 	<p>C</p> 	<p>D</p> 	<p>E</p> 
<p>Left Panel 1 PC</p>	<p>Right Panel 1 PC</p>	<p>Left Vertical Panel 1 PC</p>	<p>Right Vertical Panel 1 PC</p>	<p>Top Rail 1 PC</p>
<p>F</p> 	<p>G</p> 	<p>H</p> 	<p>I</p> 	<p>J</p> 
<p>Top Panel 1 PC</p>	<p>Bottom Panel 1 PC</p>	<p>Back Panel 2 PCS</p>	<p>Middle Back Panel 1 PC</p>	<p>Adjustable Shelf 2 PCS</p>
<p>K</p> 	<p>L</p> 	<p>M</p> 	<p>N</p> 	<p>O</p> 
<p>Middle Adjustable Shelf 1 PC</p>	<p>Left Middle Door Panel 1 PC</p>	<p>Right Middle Door Panel 1 PC</p>	<p>Left Door Panel 1 PC</p>	<p>Right Door Panel 1 PC</p>
<p>P</p> 	<p>Q</p>  <p>Use Only With Bun Feet</p>			
<p>Long Support Leg 2 PCS</p>	<p>Short Support Leg 2 PCS</p>			

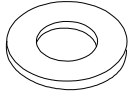
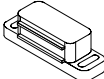
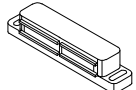
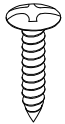
HARDWARE LIST

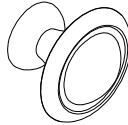
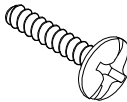
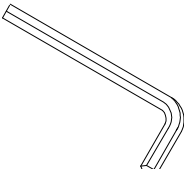
				
<p>Cam Lock 10 PCS</p>	<p>Cam Bolt 10 PCS</p>	<p>Wood Dowel 20 PCS</p>	<p>Screw 4 PCS</p>	<p>Allen Bolt 8 PCS</p>
				
<p>Spring Washer 8 PCS</p>	<p>Flat Washer 8 PCS</p>	<p>Magnet 2 PCS</p>	<p>Double Magnet 1 PC</p>	<p>Round Head Screw 13 PCS</p>
				
<p>Shelf Holder 12 PCS</p>	<p>Knob 4 PCS</p>	<p>Round Head Bolt 4 PCS</p>	<p>Allen Wrench 1 PC</p>	

ADDITIONAL TOOLS (Not Provided)

Note: It is not recommended to use power tools during assembly.

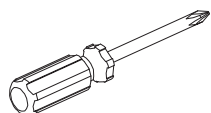

Phillips Head Screwdriver

Note: Wood dowels are intended for alignment. Additional clearance between wood dowel and pre-drilled hole is intentional for ease of assembly.

Step 1. Insert cam bolts (part #2) into left panel (part A), right panel (part B) and top panel (part F) using phillips head screwdriver.

NOTE: Do not overtighten cam bolts. Stop tightening once threads on cam bolt are no longer visible.

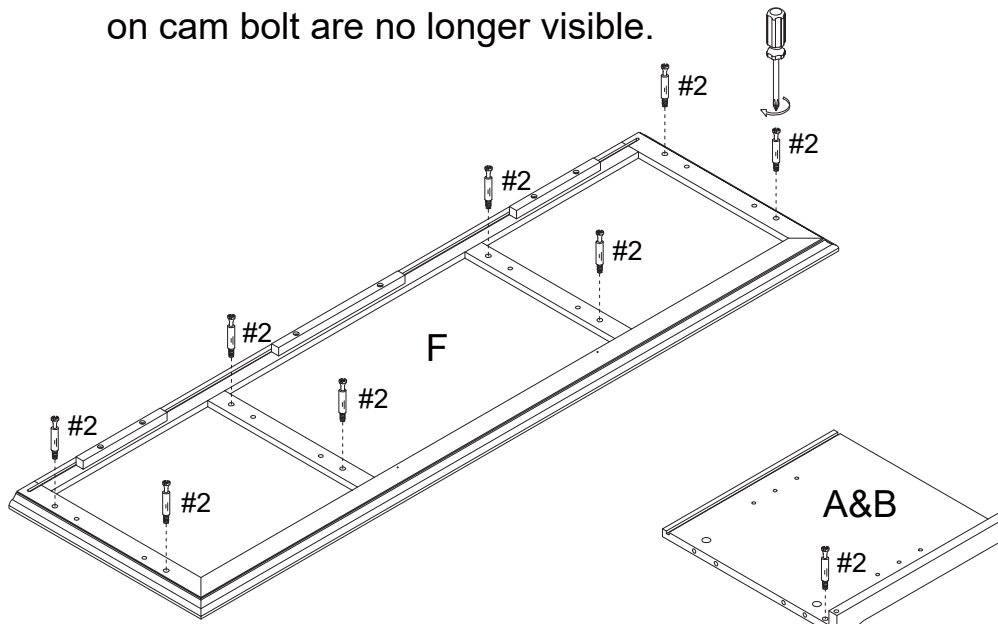

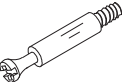
#2  X10

Step 2. Attach top rail (part E) to left vertical panel (part C) and right vertical panel (part D) using wood dowels (part #3) and screws (part #4).

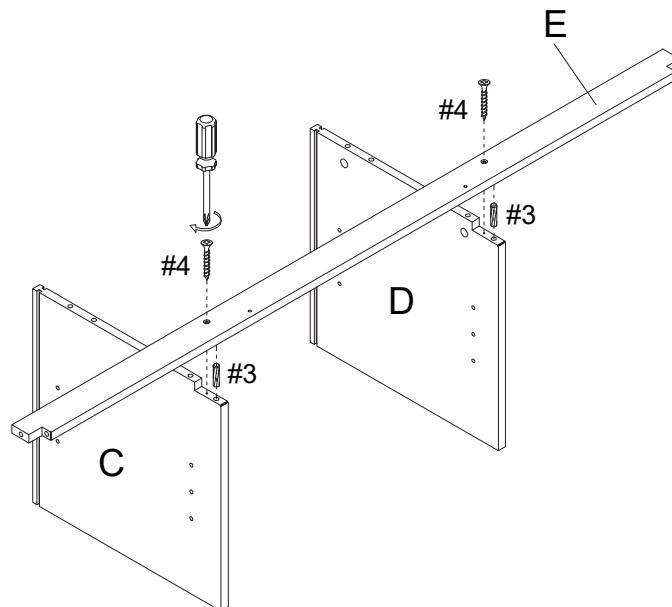

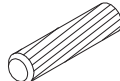
#3  X2

#4  X2

Step 3. Attach left panel (part A) and right panel (part B) to top rail (part E) using wood dowels (part #3) and cam locks (part #1).

NOTE: Cam locks must rotate full 180°. See pictured insert.

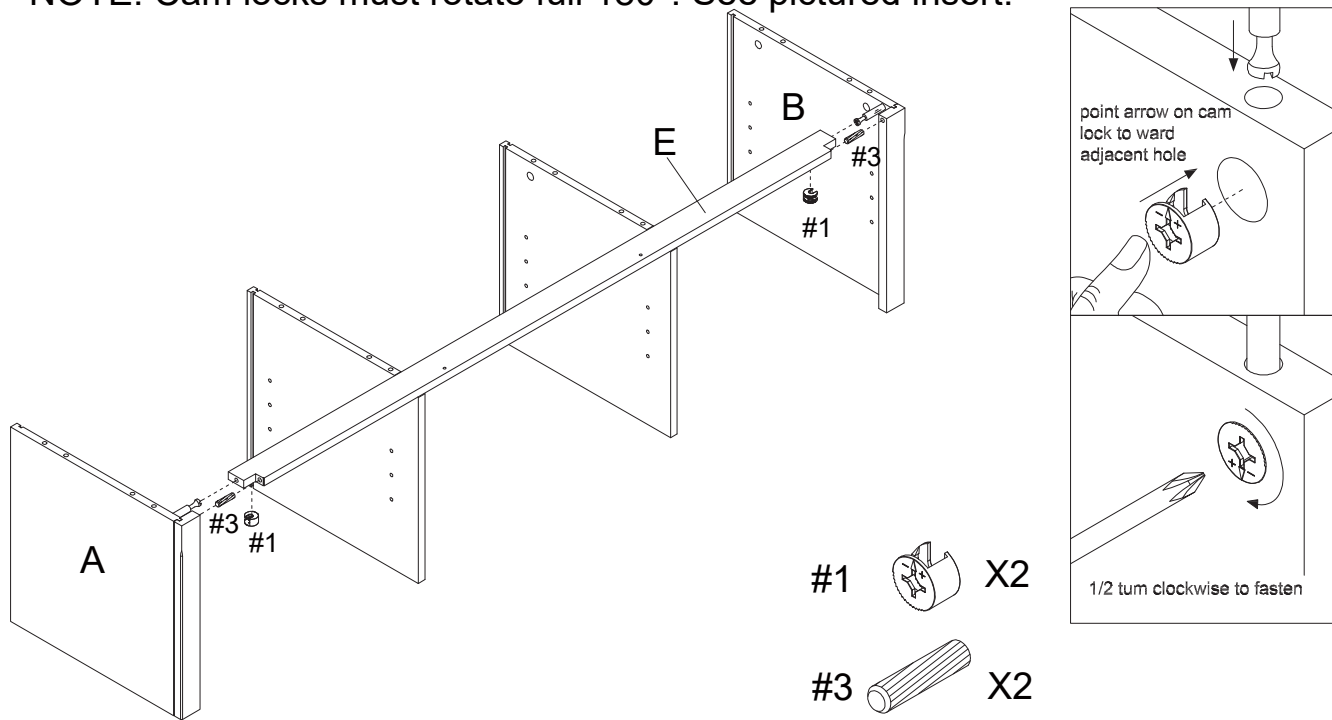

Step 4. Attach top panel (part F) to assembled unit (parts A, B, C, D & E) using wood dowels (part #3), cam locks (part #1), screws (part #4) and phillips head screwdriver.

NOTE: Cam locks must rotate full 180°. See pictured insert.

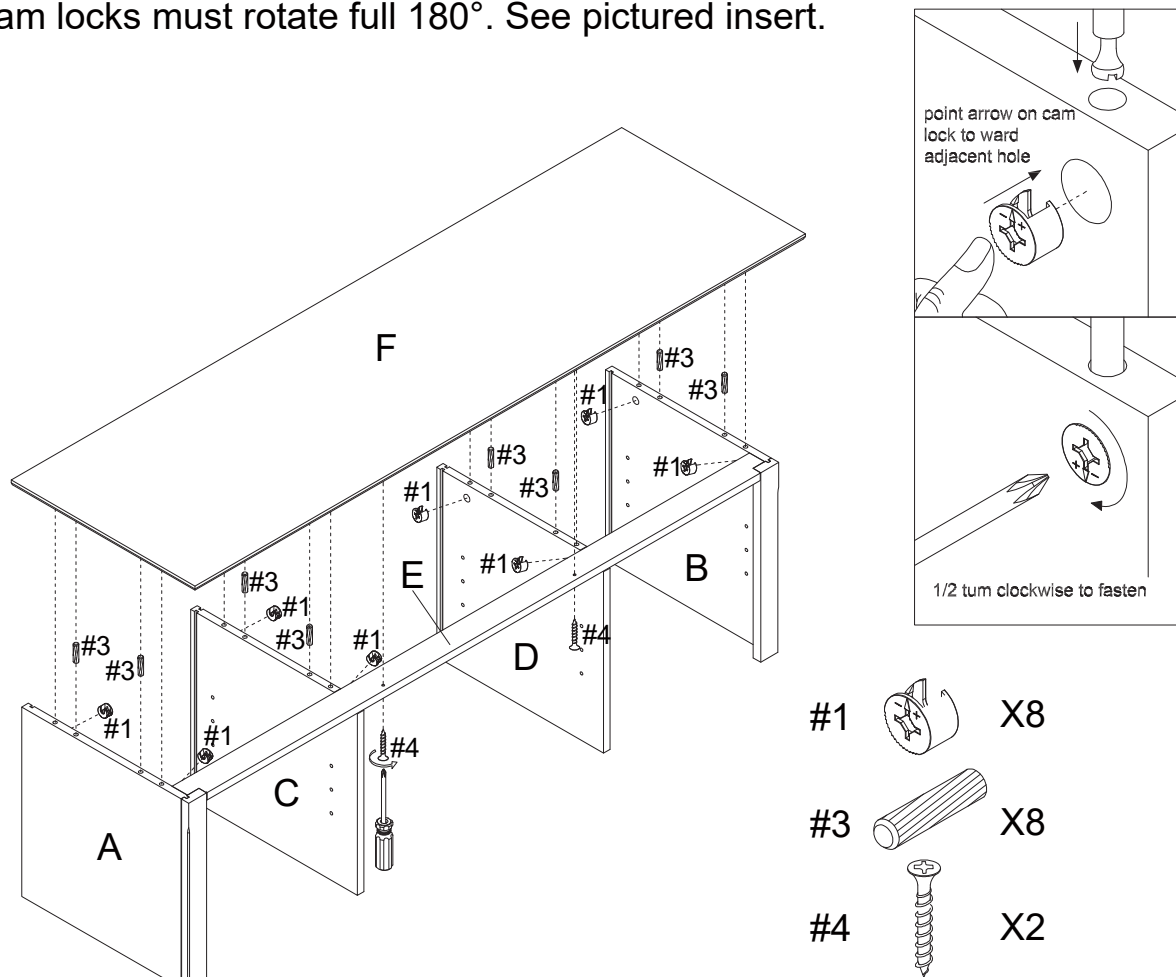

Step 5. Carefully turn unit upside down on a soft flat surface, such as carpet, as shown below. Slide back panels (part H) and middle back panel (part I) into the grooves of assembled unit (parts A, B, C, D & F).

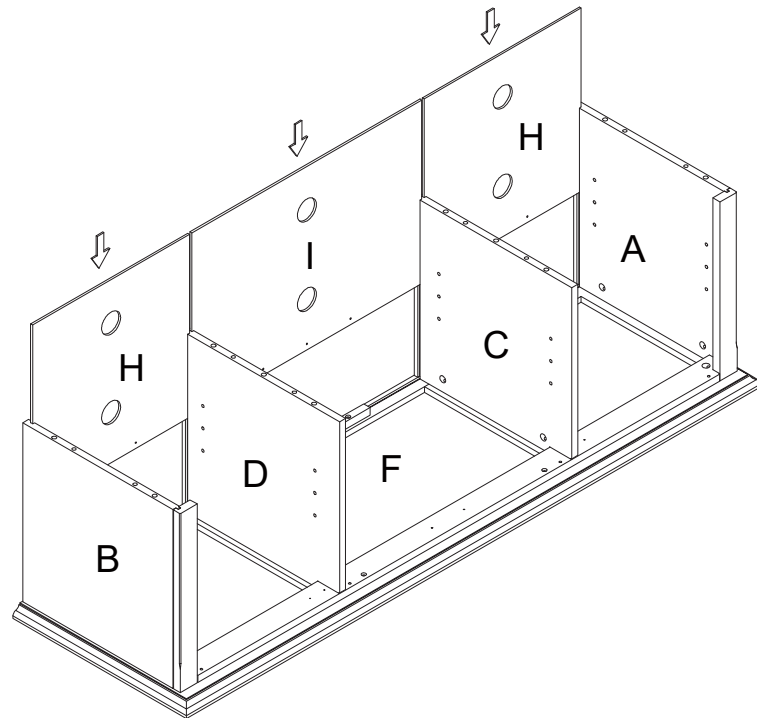

Step 6. Attach magnets (part #8) and double magnet (part #9) to top rail (part E) using round head screws (part #10) and phillips head screwdriver. Attach bottom panel (part G) to assembled unit (parts A, B, C, D, H & I) using wood dowels (part #3), allen bolts (part #5), spring washers (part #6), flat washers (part #7) and allen wrench (part #14).

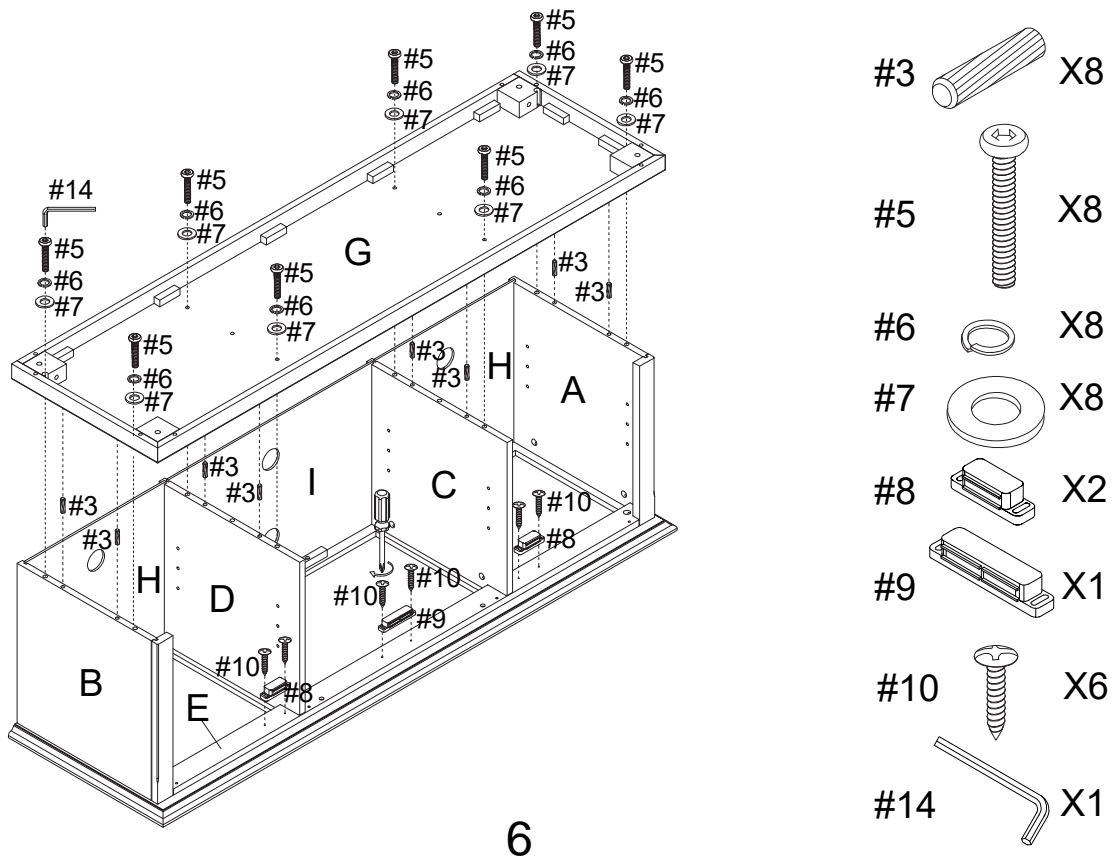

Step 7. Carefully turn unit upright. Screw round head screws (part #10) into back panels (part H) and middle back panel (part I) using phillips head screwdriver.

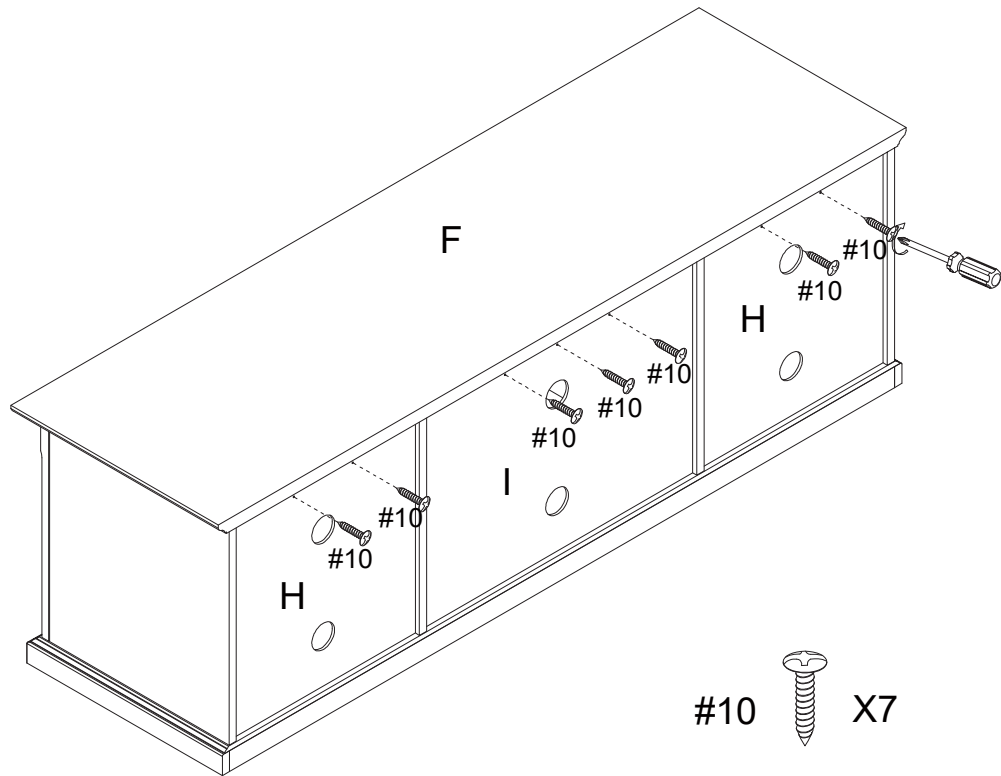

Step 8. Place shelf holders (part #11) into desired position and then slide adjustable shelves (part J) and middle adjustable shelf (part K) into place.

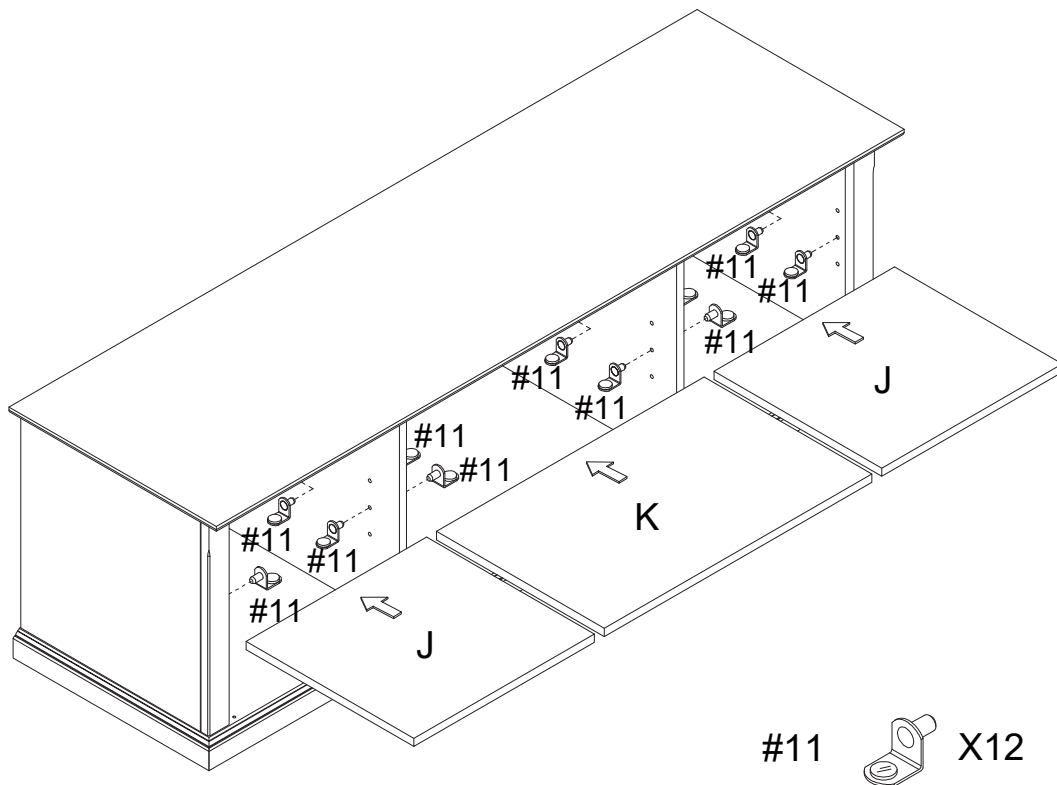

Step 9. Attach knobs (Part #12) to left middle door panel (part L), right middle door panel (part M), left door panel (part N) and right door panel (part O) using round head bolts (part #13) and phillips head screwdriver. Attach left middle door panel (part L), right middle door panel (part M), left door panel (part N) and right door panel (part O) by placing bottom pin hinge (pre-installed in door) in the pre-drilled hole of bottom panel (part G). Then depress the top spring-loaded pin hinge so it can be placed in the pre-drilled hole of top panel (part F).

NOTE: Be sure top and bottom pin hinges are fully extended to secure doors in place.

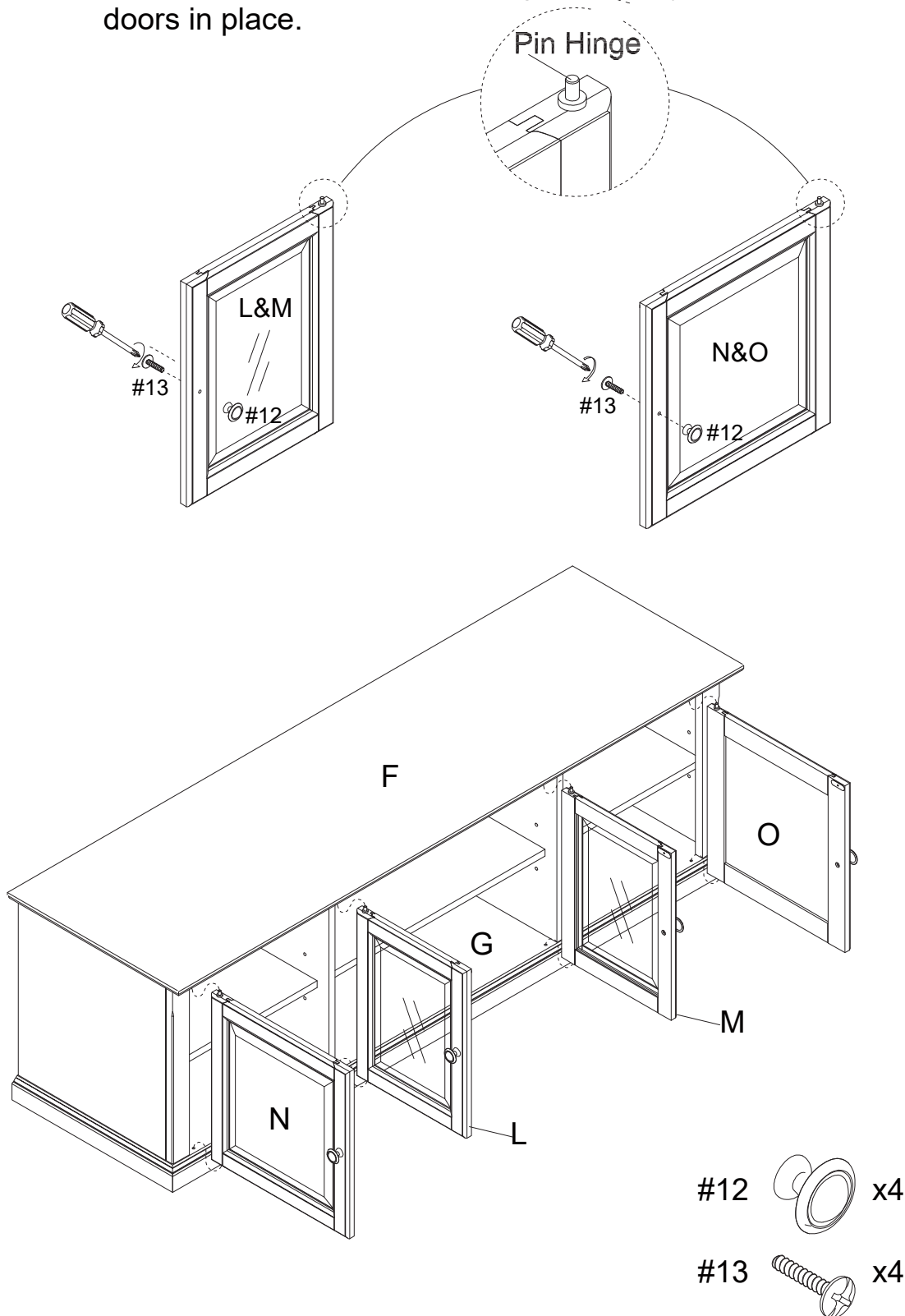

Step 10. Carefully lay unit down. Attach long support legs (part P) or short support legs (part Q) to bottom panel (part G) by turning clockwise into the center pre-drilled holes. Short support legs (part Q) should only be used with Bun Feet. All other leg styles will use long support legs (part P).

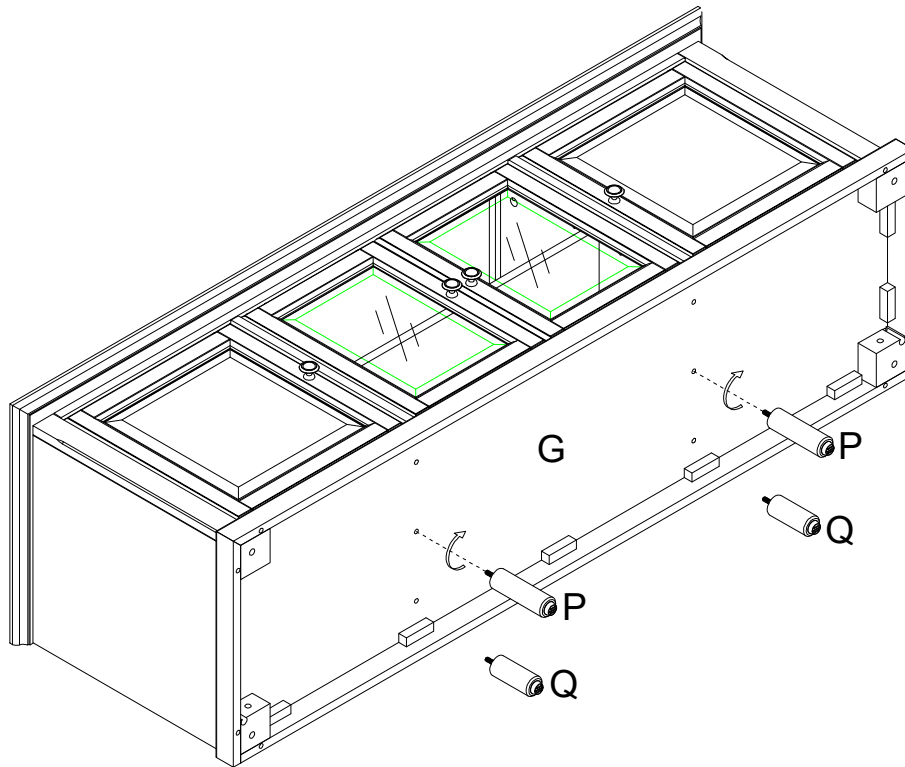

Step 11. Carefully turn unit upright.

NOTE: To support the center of unit it is important to adjust leveler on support legs once fully assembled and upright. Extend adjustable leveler until it's firmly in contact with the floor. If relocating, adjust leveler as needed until it's firmly in contact with the floor in new location.

